

# ADJUSTABLE STEP-MATE STAND, ALUMINUM - ASP-24-3-A

APPROX WEIGHT: 54.82 lbs.  
DOES NOT INCLUDE WEIGHT OF POWER OR PACKAGING!!!

\*\*\* ANY ADDITIONS, DELETIONS, OR OMISSIONS MUST BE CORRECTED ON THIS DRAWING AS THIS DRAWING WILL BE CONSIDERED ALL INCLUSIVE \*\*\*  
ALL GRAPHICS PROVIDED ARE FOR REFERENCE ONLY. IF CERTAIN DIMENSIONS ARE CRITICAL PLEASE VERIFY THOSE DIMENSIONS WITH YOUR SALESPERSON

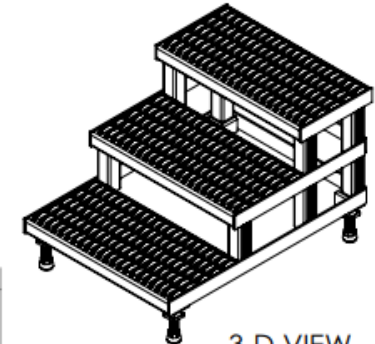
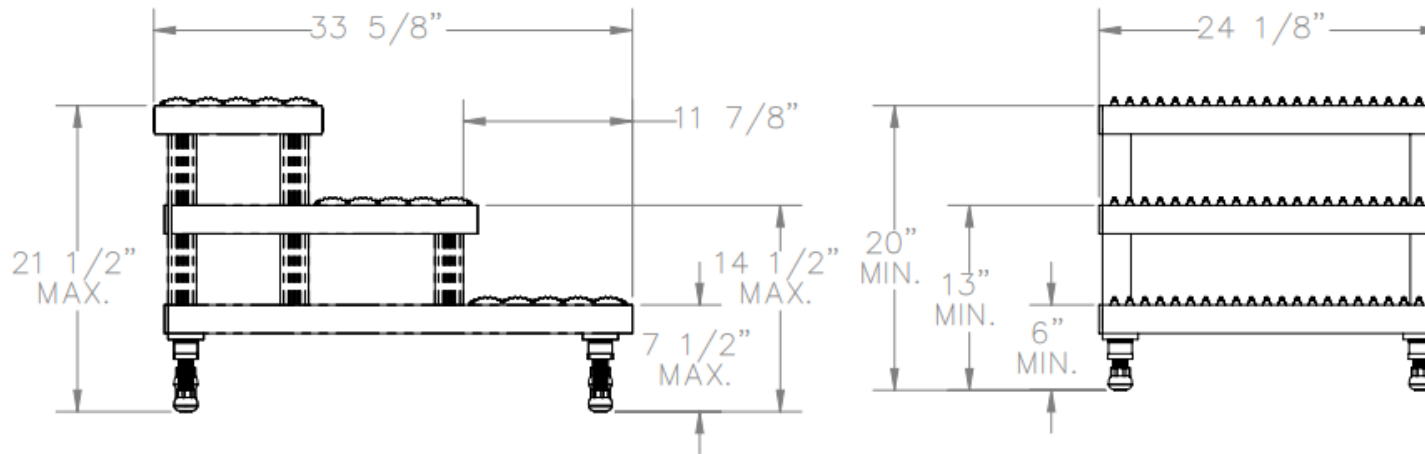

3-D VIEW  
1:20 SCALE

## STANDARD FEATURES

- MODEL NUMBER IS ASP-24-3-A
- CAPACITY: 500 LBS
- OVERALL WIDTH: 24 1/8"
- OVERALL LENGTH: 33 5/8"
- BOTTOM STEP HEIGHT: MIN. 6", MAX. 7 1/2"
- MIDDLE STEP HEIGHT: MIN. 13", MAX. 14 1/2"
- TOP STEP HEIGHT: MIN. 20", MAX. 21 1/2"
- STEPS:
  - SERRATED ALUMINUM 11 7/8" DEEP
- LEGS:
  - ADJUSTABLE
  - ANTI-SLIP TIPS
- ALUMINUM PLATFORM WITH POWDER COATED STEEL LEGS

## SPECIAL FEATURES

NONE

## DIMENSION TOLERANCE ± 1/4"

APPROVAL

I, THE UNDERSIGNED, AGREE THAT THE PRODUCT AS REPRESENTED SATISFIES DESIGN AND DIMENSION REQUIREMENTS. I ALSO ACKNOWLEDGE MY DUTY TO CONFIRM PRODUCT AND INSTALLATION COMPLIANCE WITH ALL APPLICABLE FEDERAL, STATE AND LOCAL REGULATIONS AND STANDARDS.

**ANY MODIFIED UNITS ARE NON-RETURNABLE**

As drawn       As marked

Signed: \_\_\_\_\_ Date: \_\_\_\_\_

Printed Name: \_\_\_\_\_

LEAD TIME WILL START UPON RECEIPT OF SIGNED APPROVAL DRAWING

FOR INTERNAL USE ONLY PROJECT SIGN OFF	
SALES	
ENG.	
FAB.	
POWER	

DISTRIBUTOR'S NAME:		P.O.#	X
		W.O.#	X
DRAWN BY:	BJW	DATE:	5/21/2012
REFERENCE:	X	SCALE:	1:12
QUOTED LEAD TIME:	X	QUOTE #	X
		FILE NAME:	14-007-161

...