

ADJUSTABLE STEP-MATE STAND - MODEL ASP-24-3

APPROX WEIGHT: 68.68 lbs.
DOES NOT INCLUDE WEIGHT OF POWER OR PACKAGING!!!

*** ANY ADDITIONS, DELETIONS, OR OMISSIONS MUST BE CORRECTED ON THIS DRAWING AS THIS DRAWING WILL BE CONSIDERED ALL INCLUSIVE ***
ALL GRAPHICS PROVIDED ARE FOR REFERENCE ONLY. IF CERTAIN DIMENSIONS ARE CRITICAL PLEASE VERIFY THOSE DIMENSIONS WITH YOUR SALESPERSON

3-D VIEW
1:20 SCALE

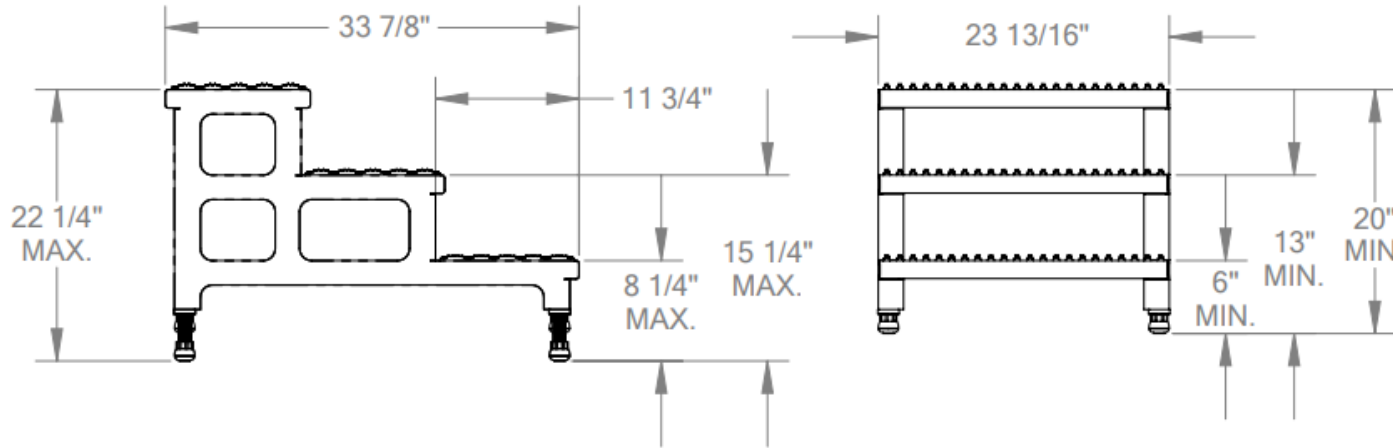
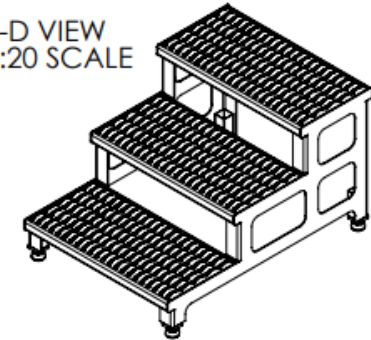

STANDARD FEATURES

- MODEL NUMBER IS ASP-24-3
- CAPACITY: 500 LBS
- OVERALL WIDTH: 23 13/16"
- OVERALL LENGTH: 33 7/8"
- BOTTOM STEP HEIGHT: MIN. 6", MAX. 8 1/4"
- MIDDLE STEP HEIGHT: MIN. 13", MAX. 15 1/4"
- TOP STEP HEIGHT: MIN. 20", MAX. 22 1/4"
- STEPS:
 - SERRATED STEEL 11 3/4" DEEP
- LEGS:
 - ADJUSTABLE
 - ANTI-SLIP TIPS
- TOUGH BAKED IN POWDER
COATED YELLOW FINISH

SPECIAL FEATURES

NONE

DIMENSION TOLERANCE ± 1/4"

APPROVAL

I, THE UNDERSIGNED, AGREE THAT THE PRODUCT AS REPRESENTED SATISFIES DESIGN AND DIMENSION REQUIREMENTS. I ALSO ACKNOWLEDGE MY DUTY TO CONFIRM PRODUCT AND INSTALLATION COMPLIANCE WITH ALL APPLICABLE FEDERAL, STATE AND LOCAL REGULATIONS AND STANDARDS.

ANY MODIFIED UNITS ARE NON-RETURNABLE

As drawn As marked

Signed: _____ Date: _____

Printed Name: _____

LEAD TIME WILL START UPON RECEIPT OF SIGNED APPROVAL DRAWING

FOR INTERNAL USE ONLY PROJECT SIGN OFF	
SALES	
ENG.	
FAB.	
POWER	

DISTRIBUTOR'S NAME:		P.O.#	X
		W.O.#	X
DRAWN BY:	W. STALEY	DATE:	12/31/08
REFERENCE:	X	SCALE:	1:14
QUOTED LEAD TIME:	X	QUOTE #	X
		FILE NAME:	14-007-091

...