

ADJUSTABLE STEP-MATE STANDS - ASP-24-3-SS

APPROX WEIGHT: 52.41 lbs.
DOES NOT INCLUDE WEIGHT OF POWER OR PACKAGING!!!

*** ANY ADDITIONS, DELETIONS, OR OMISSIONS MUST BE CORRECTED ON THIS DRAWING AS THIS DRAWING WILL BE CONSIDERED ALL INCLUSIVE ***
ALL GRAPHICS PROVIDED ARE FOR REFERENCE ONLY. IF CERTAIN DIMENSIONS ARE CRITICAL PLEASE VERIFY THOSE DIMENSIONS WITH YOUR SALESPERSON
ALL GRAPHICS PROVIDED ARE FOR REFERENCE ONLY. IF CERTAIN DIMENSIONS ARE CRITICAL PLEASE VERIFY THOSE DIMENSIONS WITH YOUR SALESPERSON

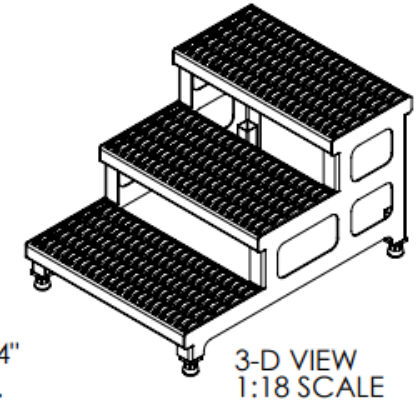
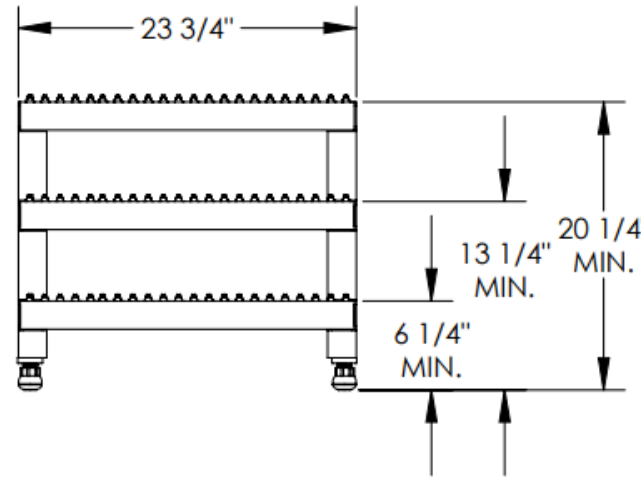
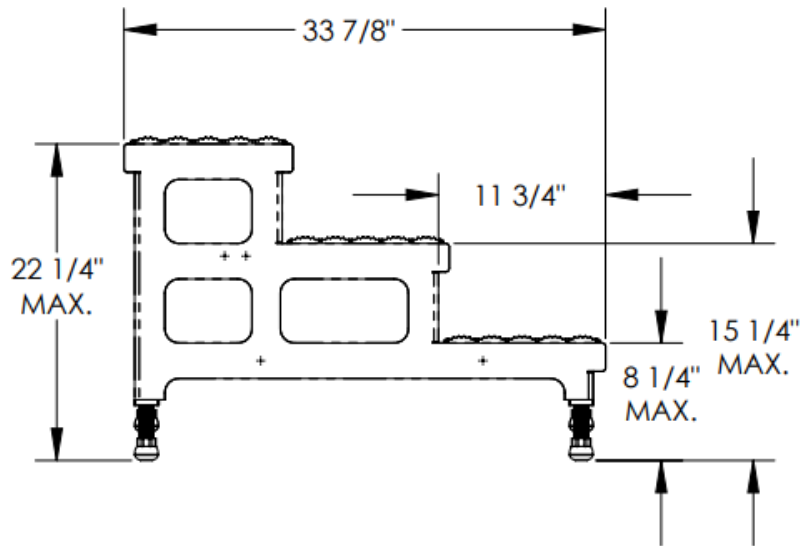

STANDARD FEATURES

- MODEL NUMBER IS ASP-24-3-SS
- CAPACITY: 500 LBS
- OVERALL WIDTH: 23 3/4"
- OVERALL LENGTH: 33 7/8"
- BOTTOM STEP HEIGHT: MIN. 6 1/4", MAX. 8 1/4"
- MIDDLE STEP HEIGHT: MIN. 13 1/4", MAX. 15 1/4"
- TOP STEP HEIGHT: MIN. 20 1/4", MAX. 22 1/4"
- STEPS:
 - SERRATED STAINLESS STEEL 11 3/4" DEEP
- LEGS:
 - ADJUSTABLE
 - ANTI-SLIP TIPS
- STAINLESS STEEL CONSTRUCTION WITH UNPOLISHED (MILL) FINISH

SPECIAL FEATURES

NONE

DIMENSION TOLERANCE ± 1/4"

I, THE UNDERSIGNED, AGREE THAT THE PRODUCT AS REPRESENTED SATISFIES DESIGN AND DIMENSION REQUIREMENTS. I ALSO ACKNOWLEDGE MY DUTY TO CONFIRM PRODUCT AND INSTALLATION COMPLIANCE WITH ALL APPLICABLE FEDERAL, STATE AND LOCAL REGULATIONS AND STANDARDS.

ANY MODIFIED UNITS ARE NON-RETURNABLE

[] As drawn [] As marked

Signed: _____ Date: _____

Printed Name: _____

LEAD TIME WILL START UPON RECEIPT OF SIGNED APPROVAL DRAWING

FOR INTERNAL USE ONLY PROJECT SIGN OFF		DISTRIBUTOR'S NAME:		P.O.#
SALES				X
ENG.				W.O.#
FAB.				X
POWER				SALES: X
		DRAWN BY: SJA	DATE: 12/12/14	FILE NAME:
		REFERENCE: X	SCALE: 1:12	14-007-297
		QUOTED LEAD TIME: X	QUOTE # X	