

ALUMINUM WALK RAMP W/ GRIP STRUT - AWR-G-28-6A

APPROX WEIGHT: 55.91 lbs.
DOES NOT INCLUDE WEIGHT OF POWER OR PACKAGING!!!

*** ANY ADDITIONS, DELETIONS, OR OMISSIONS MUST BE CORRECTED ON THIS DRAWING AS THIS DRAWING WILL BE CONSIDERED ALL INCLUSIVE ***
ALL GRAPHICS PROVIDED ARE FOR REFERENCE ONLY. IF CERTAIN DIMENSIONS ARE CRITICAL PLEASE VERIFY THOSE DIMENSIONS WITH YOUR SALESPERSON

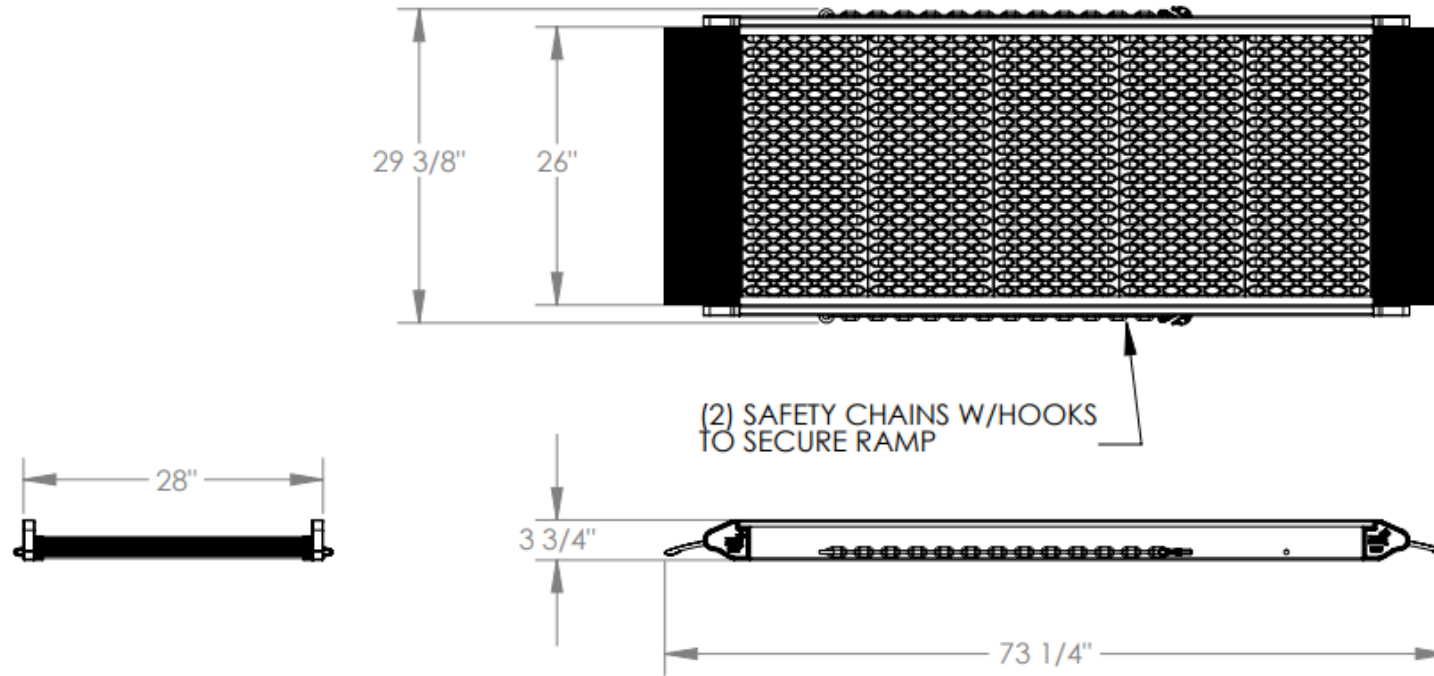

STANDARD FEATURES

MODEL NUMBER IS AWR-G-28-6A
OVERALL WIDTH IS 29 3/8"
USABLE WIDTH IS 26"
USABLE LENGTH IS 73 1/4"
4 WHEEL CART CAPACITY: 2,800 LBS.
2 WHEEL CART CAPACITY: 2,000 LBS.
HEIGHT SERVICE RANGE: 6"-21"
ALUMINUM CONSTRUCTION

SPECIAL FEATURES

NONE

DIMENSION TOLERANCE ± 1/4"

A P P R O V A L	I, THE UNDERSIGNED, AGREE THAT THE PRODUCT AS REPRESENTED SATISFIES DESIGN AND DIMENSION REQUIREMENTS. I ALSO ACKNOWLEDGE MY DUTY TO CONFIRM PRODUCT AND INSTALLATION COMPLIANCE WITH ALL APPLICABLE FEDERAL, STATE AND LOCAL REGULATIONS AND STANDARDS.	
	ANY MODIFIED UNITS ARE NON-RETURNABLE	
	[] As drawn [] As marked	
	Signed: _____	Date: _____
Printed Name: _____		
LEAD TIME WILL START UPON RECEIPT OF SIGNED APPROVAL DRAWING		

FOR INTERNAL USE ONLY PROJECT SIGN OFF		DISTRIBUTOR'S NAME: MP Industries, Inc.		P.O.# X
SALES		DRAWN BY: BCN		DATE: 10/5/2016
ENG.		REFERENCE: X	SCALE: 1:16	SALES: X
FAB.		QUOTED LEAD TIME: X	QUOTE # X	FILE NAME: 18-007-175
POWER				