

**EPFC-25-AA (ELECTRIC POWERED FLOOR CRANE WITH ADJUSTABLE LEGS)**

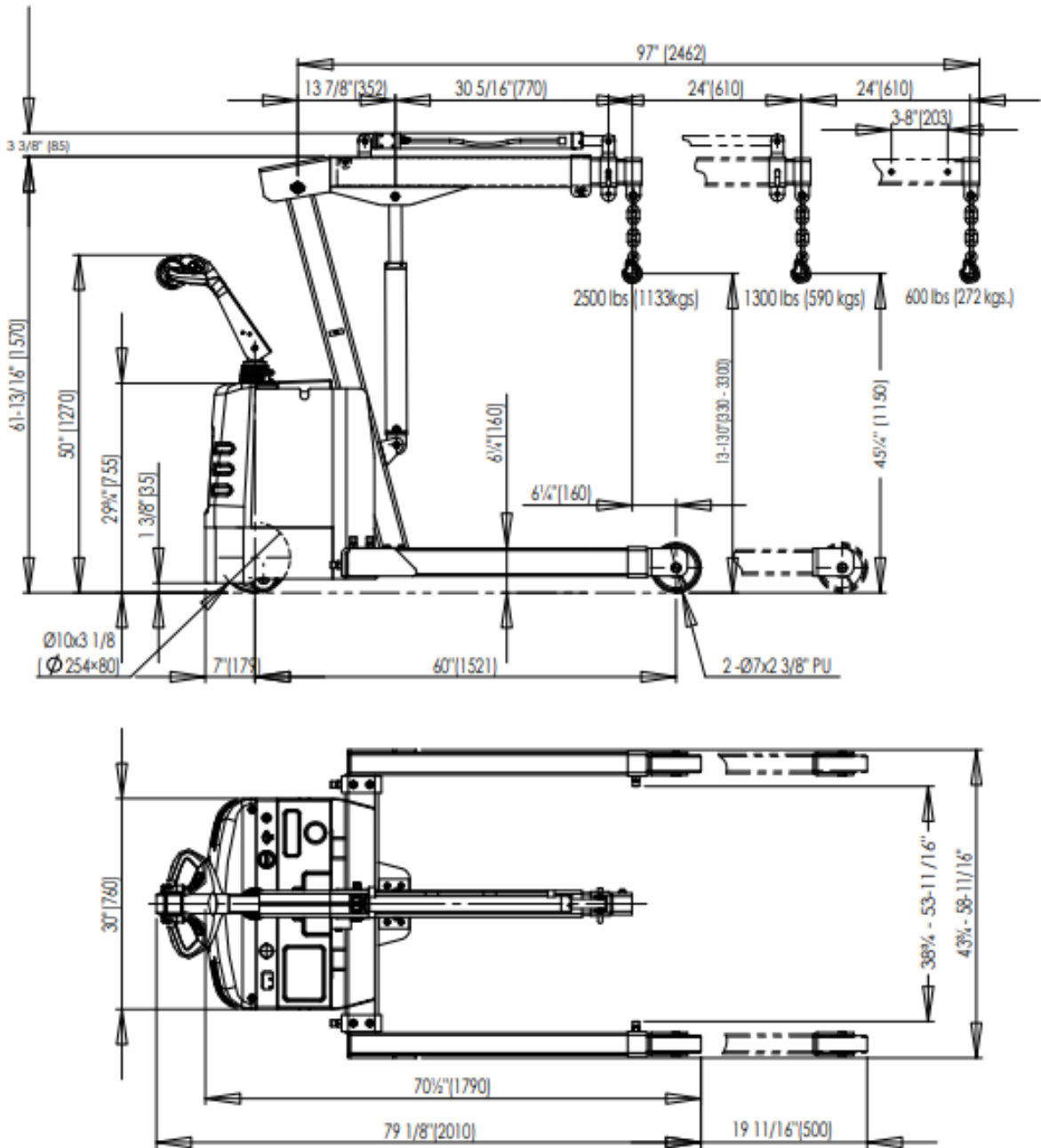

**Specifications**

Maximum Capacity (boom fully retracted): 2,500 lbs (1133 kgs)

Maximum Capacity (boom fully extended): 600 lbs (272 kgs)

Drive Motor: DC24V/0.7KW

Lift Motor: DC24V/2.0KW

Battery: 2x12V/85-95Ah

Battery Charger: 24V/12amp

Lift Speed w/o Load: 0.70"/sec

Lift Speed w/load: 1/2"/sec

Lower down speed w/o load: 1/4"/sec

Lower down speed w/load: 3/4"/sec

Travel speed w/o load: 2.8 m/h

Travel speed w/load: 2.18 m/h

Gradeability: 0%

Model:	EPFC-25-AA	
Descrip:	Electric Powered Floor Crane with straddle legs	
Design:	T.M	Date: 05/07/18