

EPFC-CB-15 (ELECTRIC POWERED COUNTER-BALANCE FLOOR CRANE)

APPROX WEIGHT: lbs. 1598
 DOES NOT INCLUDE WEIGHT OF POWER OR PACKAGING!

ANY ADDITIONS, DELETIONS, OR OMISSIONS MUST BE CORRECTED ON THIS DRAWING AS THIS DRAWING WILL BE CONSIDERED ALL INCLUSIVE

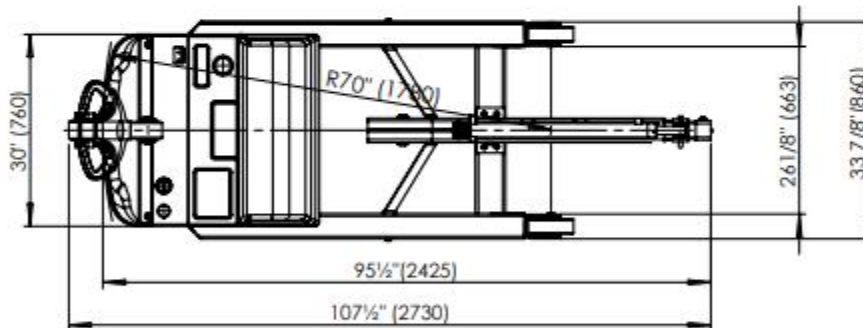
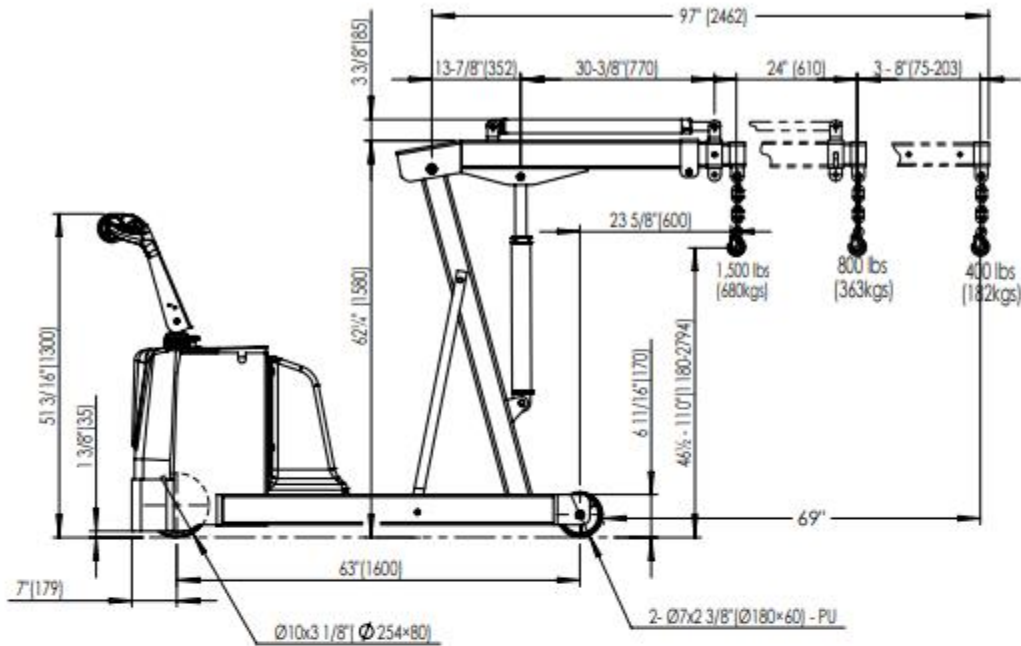

FOR INTERNAL USE ONLY
 PROJECT SIGN OFF

SALES	
ENG.	
FAB.	
POWER	

ALL GRAPHICS PROVIDED ARE FOR REFERENCE ONLY. IF CERTAIN DIMENSIONS ARE CRITICAL PLEASE VERIFY THOSE DIMENSIONS WITH YOUR SALESPERSON

SPECIFICATIONS

MAXIMUM CAPACITY (BOOM FULLY RETRACTED): 1,500 LBS (680KGS)
 MAXIMUM CAPACITY (BOOM FULLY EXTENDED): 400 LBS (180 KGS)
 DRIVE MOTOR: DC24V/0.7KW
 LIFT MOTOR: DC24V/2KW
 BATTERY: 2X12V/85-95AH
 BATTERY CHARGER: 24V/12AMP
 LIFT SPEED W/O LOAD: 0.70"/SEC
 LIFT SPEED W/LOAD: 1/2"/SEC
 LOWER DOWN SPEED W/O LOAD: 1/4"/SEC
 LOWER DOWN SPEED W/LOAD: 3/4"/SEC
 TRAVEL SPEED W/O LOAD: 2.8 m/H
 TRAVEL SPEED W/LOAD: 2.18 m/H
 GRADEABILITY: 0%
 TOUGH BAKED IN POWDER COATED
 BLACK & YELLOW FINISH

APPROVAL

I, THE UNDERSIGNED, AGREE THAT THE PRODUCT AS REPRESENTED SATISFIES DESIGN AND DIMENSION REQUIREMENTS. I ALSO ACKNOWLEDGE MY DUTY TO CONFIRM PRODUCT AND INSTALLATION COMPLIANCE WITH ALL APPLICABLE FEDERAL, STATE AND LOCAL REGULATIONS AND STANDARDS.

ANY MODIFIED UNITS ARE NON-RETURNABLE

[] As drawn [] As marked

Signed: _____ Date: _____

Printed Name: _____

LEAD TIME WILL START UPON RECEIPT OF SIGNED APPROVAL DRAWING

DISTRIBUTOR'S NAME:		P.O.#
		X
		W.O.#
		X
DRAWN BY:	DATE:	SALES:
RLH	4/6/2018	X
REFERENCE:	SCALE:	FILE NAME:
X	1:250	EPFC-CB-15
QUOTED LEAD TIME:	QUOTE #	
X	X	