

# MECHANICAL EDGE-O-DOCKLEVELER - FM-2066

APPROX WEIGHT: 483.06 lbs.  
DOES NOT INCLUDE WEIGHT OF POWER OR PACKAGING!!!

\*\*\* ANY ADDITIONS, DELETIONS, OR OMISSIONS MUST BE CORRECTED ON THIS DRAWING AS THIS DRAWING WILL BE CONSIDERED ALL INCLUSIVE \*\*\*  
ALL GRAPHICS PROVIDED ARE FOR REFERENCE ONLY. IF CERTAIN DIMENSIONS ARE CRITICAL PLEASE VERIFY THOSE DIMENSIONS WITH YOUR SALESPERSON

NOTE: HANDLE NOT SHOWN IN THIS VIEW.

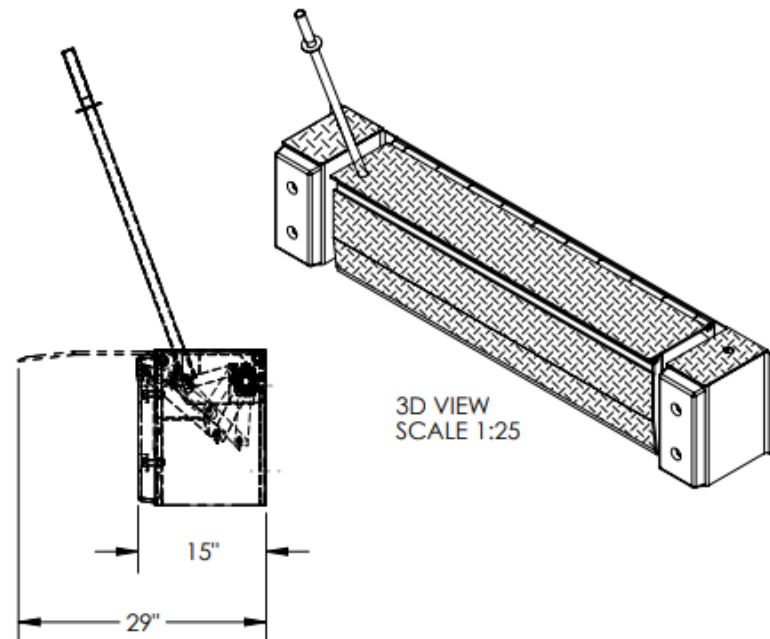
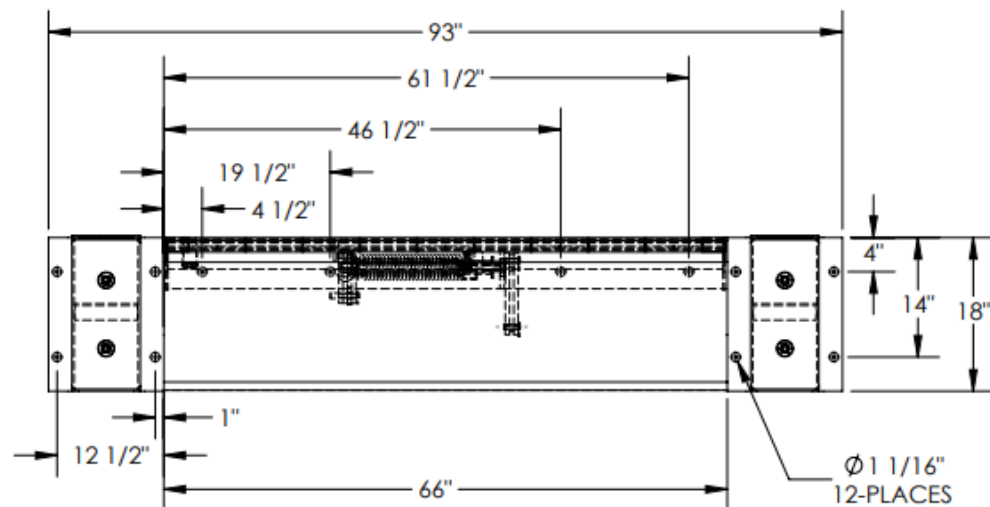

## STANDARD FEATURES

- MODEL NUMBER IS FM-2066
- DECK WIDTH IS 66"
- OVERALL WIDTH IS 93"
- MAX CAPACITY IS 20,000 LBS
- STANDARD TOE GUARDS
- GREASE ZERK FITTINGS
- 18" HIGH BUMPERS (TO SERVE LOW TRUCKS)
- ADJUSTABLE TORSION SPRING COUNTERBALANCE MECHANISM
- SERVICE RANGE OF 5" ABOVE AND BELOW DOCK
- UNIT COMES COMPLETE WITH BUMPERS AND HANDLE
- TREADPLATE RAMP & DECK CONSTRUCTION

EDGE-O-DOCKS & DOCK SEALS OR SHELTERS CAN BE USED TOGETHER.  
DOCK SEALS OR SHELTERS REQUIRE A 20" MINIMUM PROJECTION

## SPECIAL FEATURES

NONE

DIMENSION TOLERANCE ± 1/4"

<b>APPROVAL</b>	I, THE UNDERSIGNED, AGREE THAT THE PRODUCT AS REPRESENTED SATISFIES DESIGN AND DIMENSION REQUIREMENTS. I ALSO ACKNOWLEDGE MY DUTY TO CONFIRM PRODUCT AND INSTALLATION COMPLIANCE WITH ALL APPLICABLE FEDERAL, STATE AND LOCAL REGULATIONS AND STANDARDS.	
	<b>ANY MODIFIED UNITS ARE NON-RETURNABLE</b>	
	[ ] As drawn    [ ] As marked	
	Signed: _____	Date: _____
Printed Name: _____		
<b>LEAD TIME WILL START UPON RECEIPT OF SIGNED APPROVAL DRAWING</b>		

FOR INTERNAL USE ONLY  
PROJECT SIGN OFF

SALES	
ENG.	
FAB.	
POWER	

DISTRIBUTOR'S NAME:		P.O.#	X
		W.O.#	X
DRAWN BY:	MW	DATE:	01/02/2013
REFERENCE:	X	SCALE:	1:20
QUOTED LEAD TIME:	X	QUOTE #	X
		FILE NAME:	07-007-003