

MECHANICAL EDGE-O-DOCKLEVELER - FM-2072

APPROX WEIGHT: 509.72 lbs.
DOES NOT INCLUDE WEIGHT OF POWER OR PACKAGING!!!

*** ANY ADDITIONS, DELETIONS, OR OMISSIONS MUST BE CORRECTED ON THIS DRAWING AS THIS DRAWING WILL BE CONSIDERED ALL INCLUSIVE ***
ALL GRAPHICS PROVIDED ARE FOR REFERENCE ONLY. IF CERTAIN DIMENSIONS ARE CRITICAL PLEASE VERIFY THOSE DIMENSIONS WITH YOUR SALESPERSON

NOTE: HANDLE NOT SHOWN IN THIS VIEW

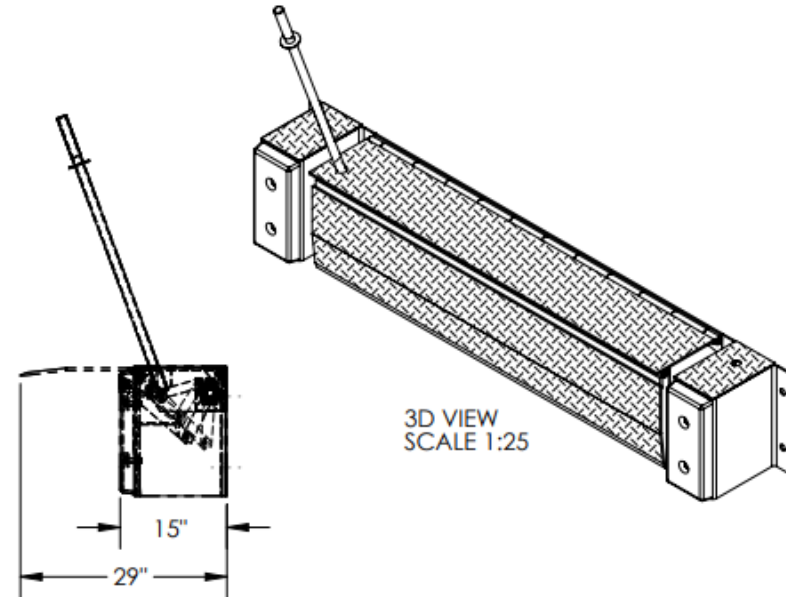
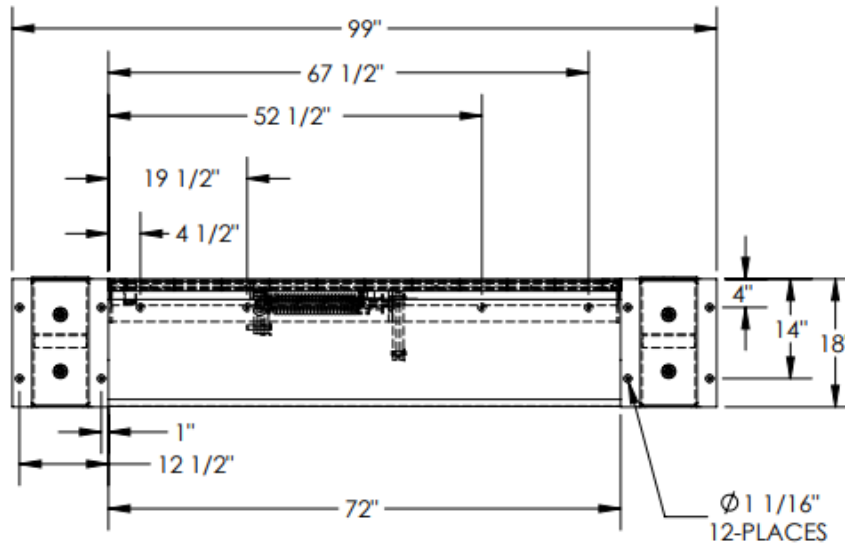

STANDARD FEATURES

- MODEL NUMBER IS FM-2072
- DECK WIDTH IS 72"
- OVERALL WIDTH IS 99"
- MAX CAPACITY IS 20,000 LBS
- STANDARD TOE GUARDS
- GREASE ZERK FITTINGS
- 18" HIGH BUMPERS (TO SERVE LOW TRUCKS)
- ADJUSTABLE TORSION SPRING COUNTERBALANCE MECHANISM
- SERVICE RANGE OF 5" ABOVE AND BELOW DOCK
- UNIT COMES WITH HANDLE AND BUMPERS
- TREADPLATE RAMP & DECK CONSTRUCTION

EDGE-O-DOCKS & DOCK SEALS OR SHELTERS CAN BE USED TOGETHER.
DOCK SEALS OR SHELTERS REQUIRE A 20" MINIMUM PROJECTION

SPECIAL FEATURES

NONE

DIMENSION TOLERANCE ± 1/4"

APPROVAL	I, THE UNDERSIGNED, AGREE THAT THE PRODUCT AS REPRESENTED SATISFIES DESIGN AND DIMENSION REQUIREMENTS. I ALSO ACKNOWLEDGE MY DUTY TO CONFIRM PRODUCT AND INSTALLATION COMPLIANCE WITH ALL APPLICABLE FEDERAL, STATE AND LOCAL REGULATIONS AND STANDARDS.	
	ANY MODIFIED UNITS ARE NON-RETURNABLE	
	[] As drawn [] As marked	
	Signed: _____	Date: _____
Printed Name: _____		
<i>LEAD TIME WILL START UPON RECEIPT OF SIGNED APPROVAL DRAWING</i>		

FOR INTERNAL USE ONLY PROJECT SIGN OFF		DISTRIBUTOR'S NAME:		P.O.#
SALES				X
ENG.		DRAWN BY: MW	DATE: 01/02/2013	W.O.#
FAB.		REFERENCE: X	SCALE: 1:24	X
POWER		QUOTED LEAD TIME: X	QUOTE # X	FILE NAME:
				07-007-002