

MECHANICAL EDGE-O-DOCKLEVELER - FM-3072

APPROX WEIGHT: 671.51 lbs.
DOES NOT INCLUDE WEIGHT OF POWER OR PACKAGING!!!

*** ANY ADDITIONS, DELETIONS, OR OMISSIONS MUST BE CORRECTED ON THIS DRAWING AS THIS DRAWING WILL BE CONSIDERED ALL INCLUSIVE ***
ALL GRAPHICS PROVIDED ARE FOR REFERENCE ONLY. IF CERTAIN DIMENSIONS ARE CRITICAL PLEASE VERIFY THOSE DIMENSIONS WITH YOUR SALESPERSON

NOTE: HANDLE NOT SHOWN IN THIS VIEW

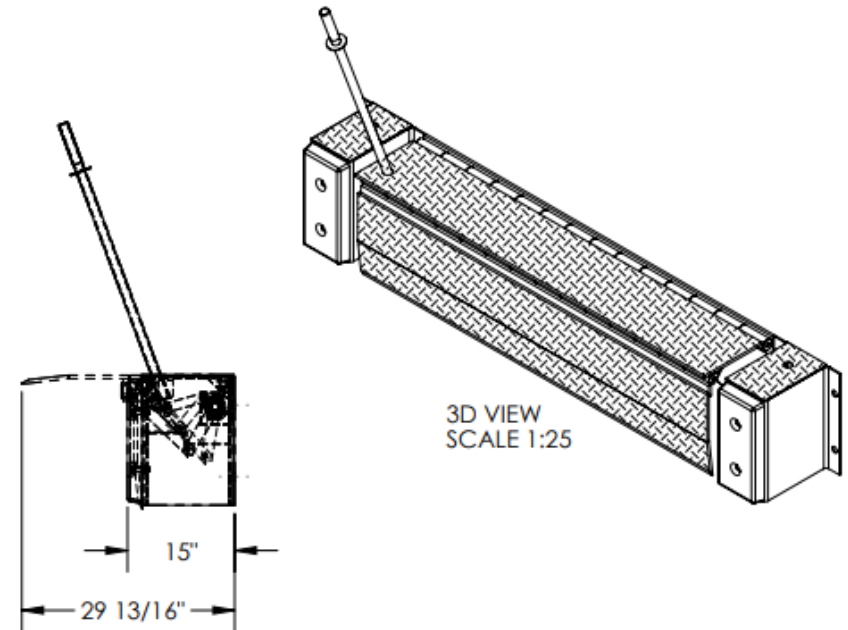
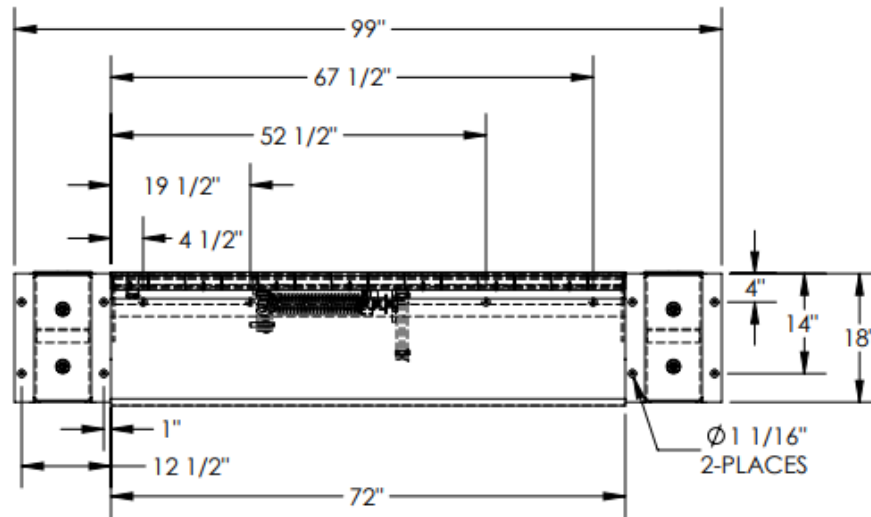

STANDARD FEATURES

- MODEL NUMBER IS FM-3072
- DECK WIDTH IS 72"
- OVERALL WIDTH IS 99"
- MAX CAPACITY IS 30,000 LBS
- STANDARD TOE GUARDS
- GREASE ZERK FITTINGS
- 18" HIGH BUMPERS (TO SERVE LOW TRUCKS)
- ADJUSTABLE TORSION SPRING COUNTERBALANCE MECHANISM
- SERVICE RANGE OF 5" ABOVE AND BELOW DOCK
- UNIT COMES WITH HANDLE AND BUMPERS
- TREADPLATE RAMP & DECK CONSTRUCTION

EDGE-O-DOCKS & DOCK SEALS OR SHELTERS CAN BE USED TOGETHER.
DOCK SEALS & SHELTERS REQUIRE A 20" MINIMUM PROJECTION.

SPECIAL FEATURES

NONE

DIMENSION TOLERANCE ± 1/4"

APPROVAL

I, THE UNDERSIGNED, AGREE THAT THE PRODUCT AS REPRESENTED SATISFIES DESIGN AND DIMENSION REQUIREMENTS. I ALSO ACKNOWLEDGE MY DUTY TO CONFIRM PRODUCT AND INSTALLATION COMPLIANCE WITH ALL APPLICABLE FEDERAL, STATE AND LOCAL REGULATIONS AND STANDARDS.

ANY MODIFIED UNITS ARE NON-RETURNABLE

As drawn As marked

Signed: _____ Date: _____

Printed Name: _____

LEAD TIME WILL START UPON RECEIPT OF SIGNED APPROVAL DRAWING

| | | | | |
|---|--|---------------------|----------------|------------|
| FOR INTERNAL USE ONLY PROJECT SIGN OFF | | DISTRIBUTOR'S NAME: | | P.O.# |
| SALES | | | | X |
| ENG. | | | | W.O.# |
| FAB. | | | | X |
| POWER | | DRAWN BY: M.WILSON | DATE: 1/2/2013 | SALES: X |
| | | REFERENCE: X | SCALE: 1:24 | FILE NAME: |
| | | QUOTED LEAD TIME: X | QUOTE # | 07-007-070 |