

# PORTABLE GAS POWERED DRUM CRUSHER - HDC-900-GPT

\*\*\*ANY ADDITIONS, DELETIONS, OR OMISSIONS MUST BE CORRECTED ON THIS DRAWING AS THIS DRAWING WILL BE CONSIDERED ALL INCLUSIVE\*\*\*

APPROX WEIGHT: 2420.8346 lbs.

DOES NOT INCLUDE WEIGHT OF POWER OR PACKAGING!!

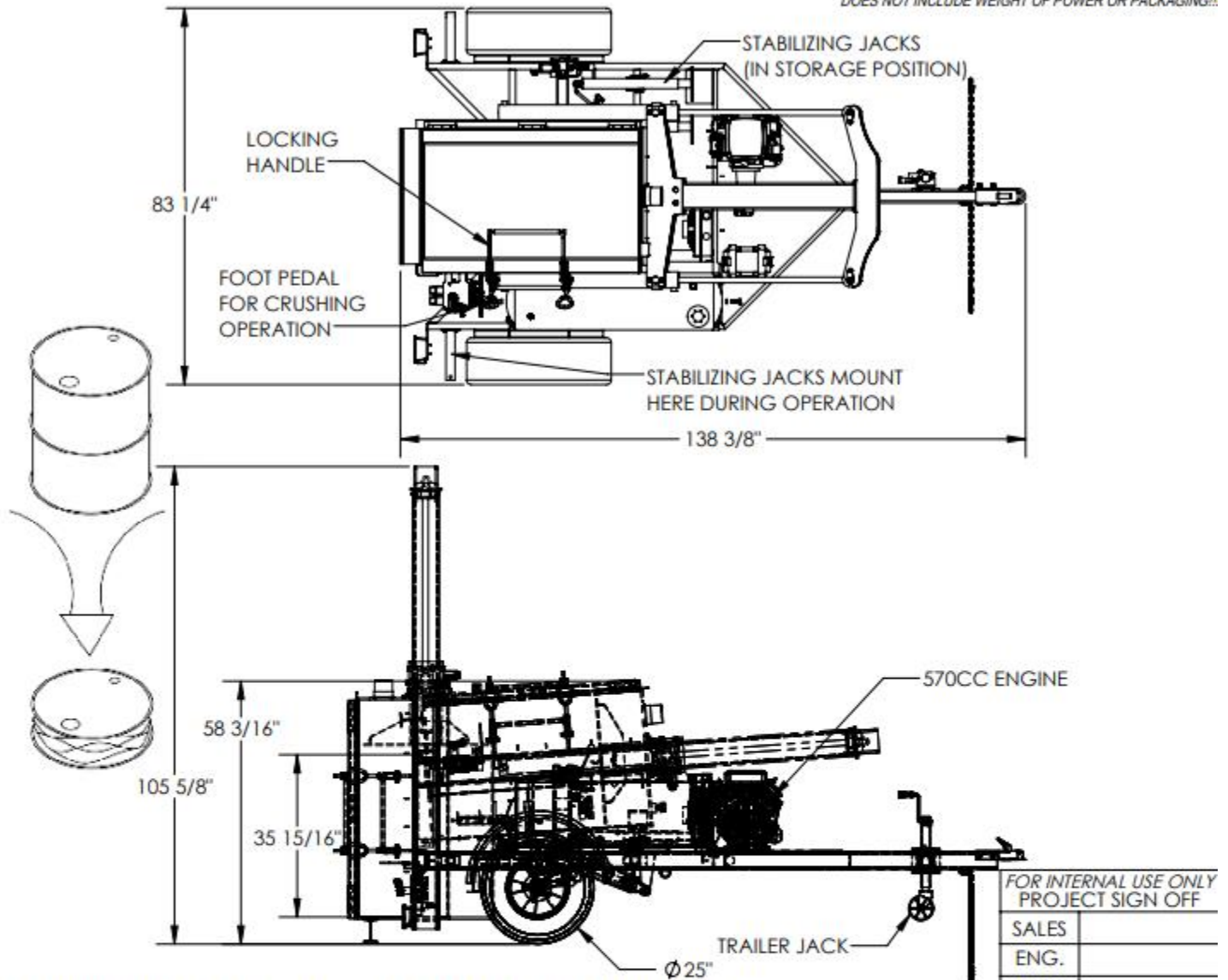

ALL GRAPHICS PROVIDED ARE FOR REFERENCE ONLY. IF CERTAIN DIMENSIONS ARE CRITICAL PLEASE VERIFY THOSE DIMENSIONS WITH YOUR SALESPERSON

DIMENSION TOLERANCE  $\pm 1/4"$

## STANDARD FEATURES

- MODEL NUMBER IS HDC-900-GPT
- CAPACITY IS (1) 55 GALLON DRUM
- OVERALL WIDTH IS 83 1/4"
- OVERALL LENGTH (TRANSPORT) IS 138 3/8"
- OVERALL HEIGHT IS 105 5/8"
- OVERALL HEIGHT (TRANSPORT) IS 58 3/16"
- USABLE HEIGHT IS 35 15/16"
- 570CC BRIGGS & STRATTON GASOLINE ENGINE

CUSTOMER IS RESPONSIBLE FOR TITLING, REGISTERING, AND PLATING THIS PRODUCT IF REQUIRED BY YOUR STATE MOTOR VEHICLE AUTHORITY.

## SPECIAL FEATURES

NONE

APPROVAL

I, THE UNDERSIGNED, AGREE THAT THE PRODUCT AS REPRESENTED SATISFIES DESIGN AND DIMENSION REQUIREMENTS. I ALSO ACKNOWLEDGE MY DUTY TO CONFIRM PRODUCT AND INSTALLATION COMPLIANCE WITH ALL APPLICABLE FEDERAL, STATE AND LOCAL REGULATIONS AND STANDARDS.

**ANY MODIFIED UNITS ARE NON-RETURNABLE**

As drawn     As marked

Signed: \_\_\_\_\_ Date: \_\_\_\_\_

Printed Name: \_\_\_\_\_

LEAD TIME WILL START UPON RECEIPT OF SIGNED APPROVAL DRAWING

DISTRIBUTOR'S NAME:		P.O.#	X
		W.O.#	X
DRAWN BY:	X	DATE:	XX/XX/XX
REFERENCE:	X	SCALE:	1:32
QUOTED LEAD TIME:	X	QUOTE #	X
		FILE NAME:	22-007-014