

LONG DECK CART - LDLT-30120

APPROX WEIGHT: 924.58 lbs.
DOES NOT INCLUDE WEIGHT OF POWER OR PACKAGING!!!

*** ANY ADDITIONS, DELETIONS, OR OMISSIONS MUST BE CORRECTED ON THIS DRAWING AS THIS DRAWING WILL BE CONSIDERED ALL INCLUSIVE ***
ALL GRAPHICS PROVIDED ARE FOR REFERENCE ONLY. IF CERTAIN DIMENSIONS ARE CRITICAL PLEASE VERIFY THOSE DIMENSIONS WITH YOUR SALESPERSON

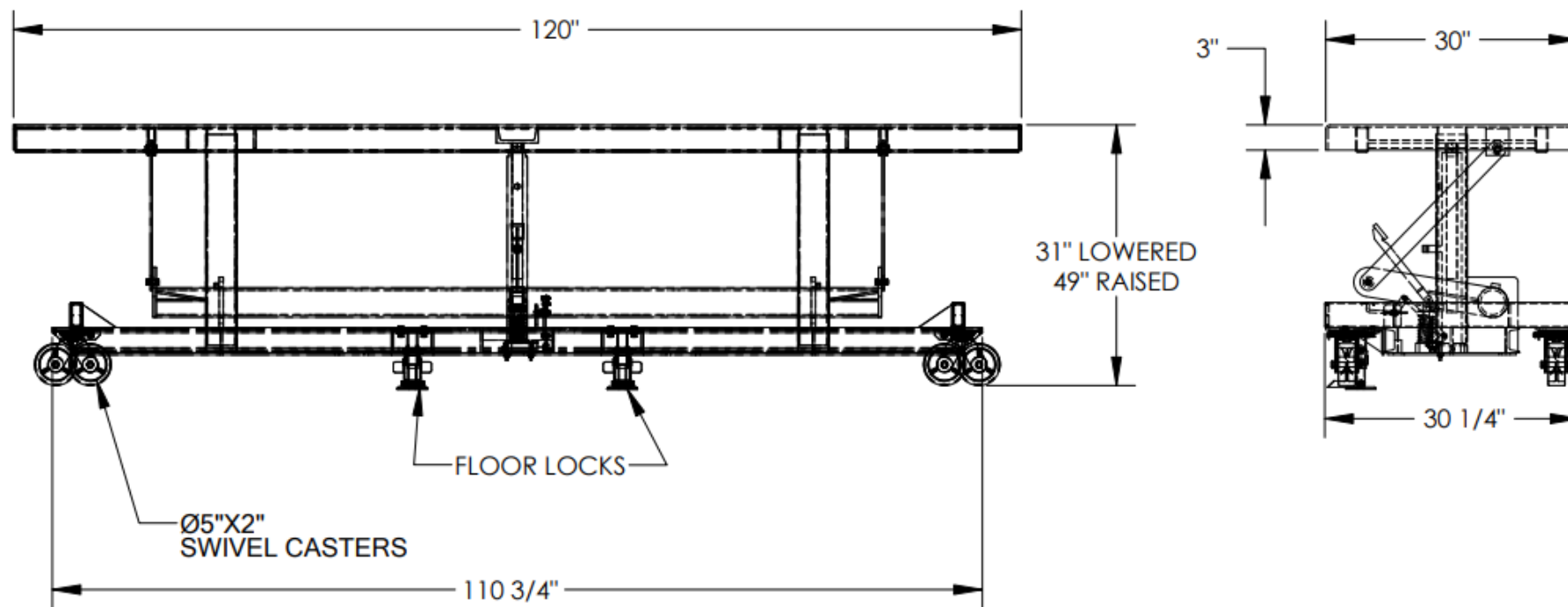

DIMENSION TOLERANCE ± 1/4"

STANDARD FEATURES

MODEL NUMBER IS LDLT-30120
CAPACITY IS 2000 LBS. (EVENLY DISTRIBUTED)
PLATFORM WIDTH IS 30"
FRAME WIDTH IS 30 1/4"
PLATFORM LENGTH IS 120"
FRAME LENGTH IS 110 3/4"
PLATFORM RAISED HEIGHT IS 49"
PLATFORM LOWERED HEIGHT IS 31"
FOUR SWIVEL 5"X2" POLY-ON-STEEL CASTERS
DUAL FLOOR LOCKS
MANUAL FOOT PUMP OPERATION
LIQUID PAINTED BLUE FINISH

SPECIAL FEATURES

NONE

APPROVAL

I, THE UNDERSIGNED, AGREE THAT THE PRODUCT AS REPRESENTED SATISFIES DESIGN AND DIMENSION REQUIREMENTS. I ALSO ACKNOWLEDGE MY DUTY TO CONFIRM PRODUCT AND INSTALLATION COMPLIANCE WITH ALL APPLICABLE FEDERAL, STATE AND LOCAL REGULATIONS AND STANDARDS.

ANY MODIFIED UNITS ARE NON-RETURNABLE

As drawn As marked

Signed: _____ Date: _____

Printed Name: _____

LEAD TIME WILL START UPON RECEIPT OF SIGNED APPROVAL DRAWING

FOR INTERNAL USE ONLY PROJECT SIGN OFF	
SALES	
ENG.	
FAB.	
POWER	

DISTRIBUTOR'S NAME:		P.O.#	X
		W.O.#	X
DRAWN BY:	SR	DATE:	10/26/06
REFERENCE:	X	SCALE:	1:18
QUOTED LEAD TIME:	X	QUOTE #	X
		FILE NAME:	21-007-057