

# LONG DECK CART - LDLT-3072-4

APPROX WEIGHT: 527.06 lbs.  
DOES NOT INCLUDE WEIGHT OF POWER OR PACKAGING!!!

\*\*\* ANY ADDITIONS, DELETIONS, OR OMISSIONS MUST BE CORRECTED ON THIS DRAWING AS THIS DRAWING WILL BE CONSIDERED ALL INCLUSIVE \*\*\*  
ALL GRAPHICS PROVIDED ARE FOR REFERENCE ONLY. IF CERTAIN DIMENSIONS ARE CRITICAL PLEASE VERIFY THOSE DIMENSIONS WITH YOUR SALESPERSON

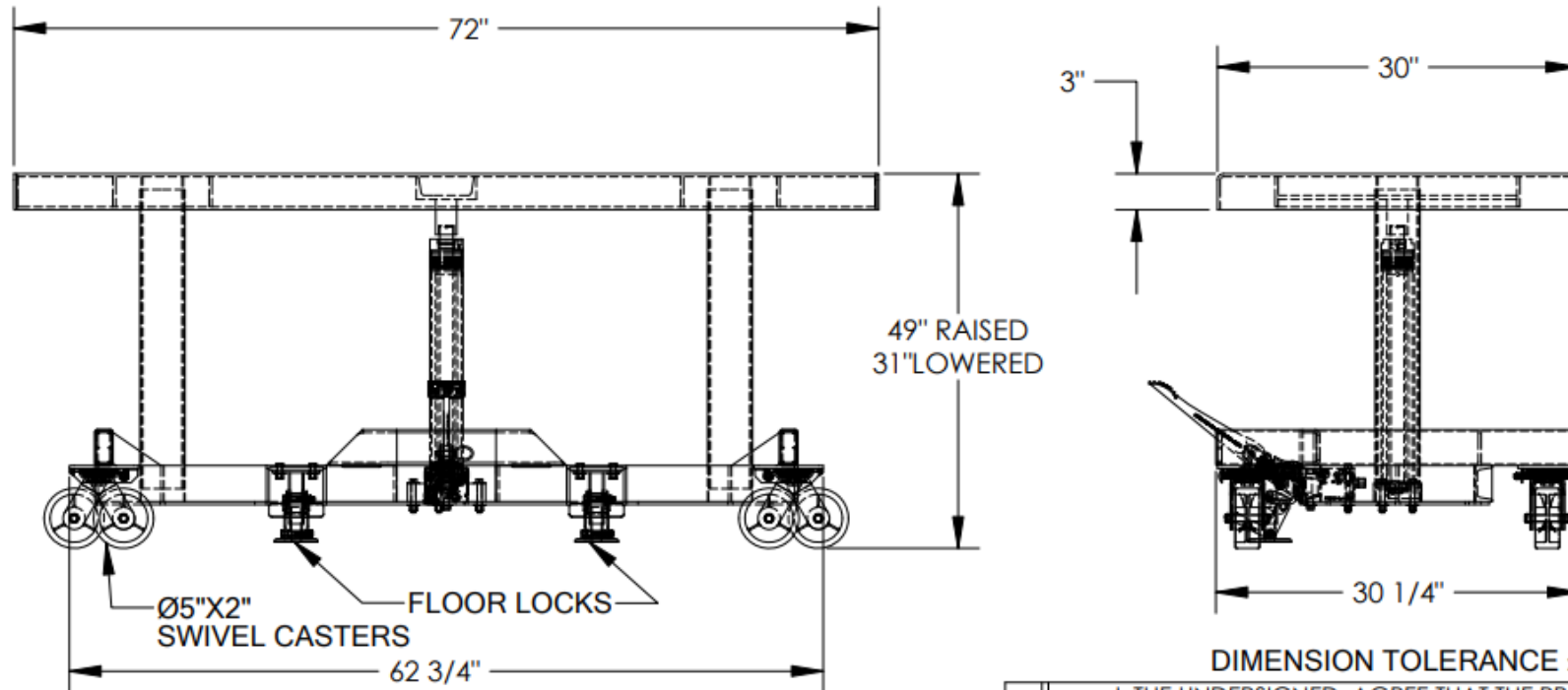

DIMENSION TOLERANCE ± 1/4"

## STANDARD FEATURES

MODEL NUMBER IS LDLT-3072-4  
CAPACITY IS 4000 LBS. (EVENLY DISTRIBUTED)  
PLATFORM WIDTH IS 30"  
FRAME WIDTH IS 30 1/4"  
PLATFORM LENGTH IS 72"  
FRAME LENGTH IS 62 3/4"  
PLATFORM RAISED HEIGHT IS 49"  
PLATFORM LOWERED HEIGHT IS 31"  
FOUR SWIVEL 5" X 2" POLY-ON-STEEL CASTERS  
DUAL FLOOR LOCKS  
MANUAL FOOT PUMP OPERATION  
LIQUID PAINTED BLUE FINISH

## SPECIAL FEATURES

NONE

**A P P R O V A L**

I, THE UNDERSIGNED, AGREE THAT THE PRODUCT AS REPRESENTED SATISFIES DESIGN AND DIMENSION REQUIREMENTS. I ALSO ACKNOWLEDGE MY DUTY TO CONFIRM PRODUCT AND INSTALLATION COMPLIANCE WITH ALL APPLICABLE FEDERAL, STATE AND LOCAL REGULATIONS AND STANDARDS.  
**ANY MODIFIED UNITS ARE NON-RETURNABLE**  
[ ] As drawn [ ] As marked

Signed: \_\_\_\_\_ Date: \_\_\_\_\_  
Printed Name: \_\_\_\_\_  
LEAD TIME WILL START UPON RECEIPT OF SIGNED APPROVAL DRAWING

FOR INTERNAL USE ONLY PROJECT SIGN OFF		DISTRIBUTOR'S NAME:		P.O.#
SALES				X
ENG.		DRAWN BY: RAL	DATE: 6/01/16	W.O.#
FAB.		REFERENCE: X	SCALE: 1:14	X
POWER		QUOTED LEAD TIME: X	QUOTE #	FILE NAME:
			X	21-007-126