

LONG DECK CART - LDLT-3072

APPROX WEIGHT: 521.63 lbs.
DOES NOT INCLUDE WEIGHT OF POWER OR PACKAGING!!!

*** ANY ADDITIONS, DELETIONS, OR OMISSIONS MUST BE CORRECTED ON THIS DRAWING AS THIS DRAWING WILL BE CONSIDERED ALL INCLUSIVE ***
ALL GRAPHICS PROVIDED ARE FOR REFERENCE ONLY. IF CERTAIN DIMENSIONS ARE CRITICAL PLEASE VERIFY THOSE DIMENSIONS WITH YOUR SALESPERSON

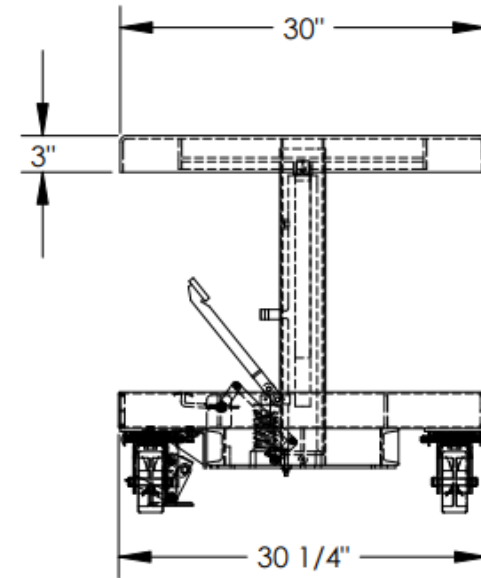
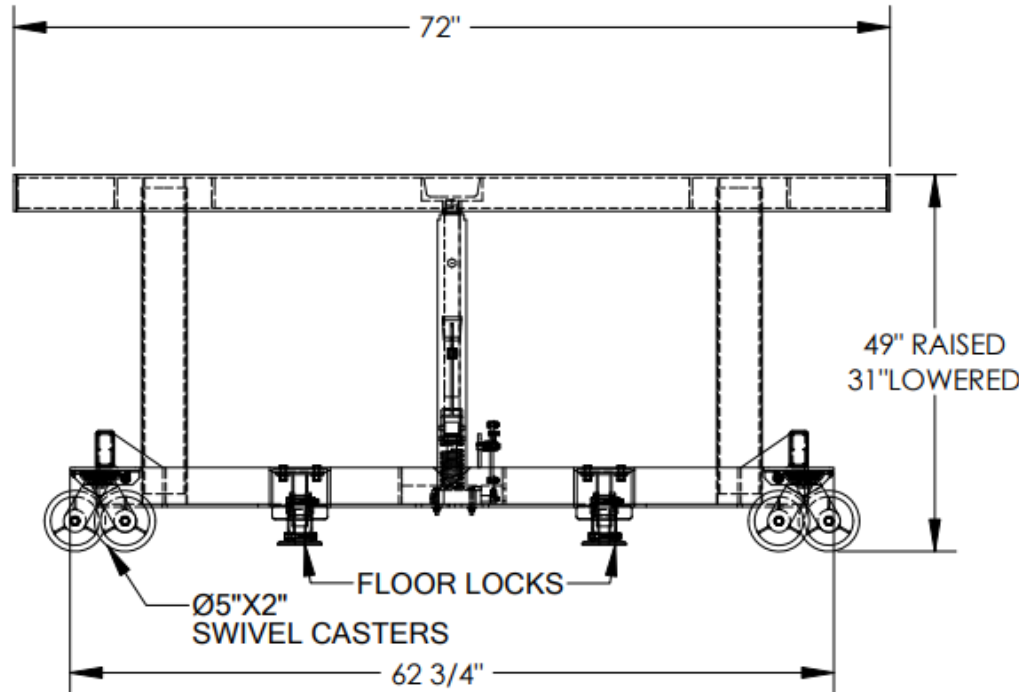

DIMENSION TOLERANCE ± 1/4"

STANDARD FEATURES

- MODEL NUMBER IS LDLT-3072
- CAPACITY IS 2000 LBS. (EVENLY DISTRIBUTED)
- PLATFORM WIDTH IS 30"
- FRAME WIDTH IS 30 1/4"
- PLATFORM LENGTH IS 72"
- FRAME LENGTH IS 62 3/4"
- PLATFORM RAISED HEIGHT IS 49"
- PLATFORM LOWERED HEIGHT IS 31"
- FOUR SWIVEL 5" X 2" POLY-ON-STEEL CASTERS
- DUAL FLOOR LOCKS
- MANUAL FOOT PUMP OPERATION
- LIQUID PAINTED BLUE FINISH

SPECIAL FEATURES

NONE

APPROVAL

I, THE UNDERSIGNED, AGREE THAT THE PRODUCT AS REPRESENTED SATISFIES DESIGN AND DIMENSION REQUIREMENTS. I ALSO ACKNOWLEDGE MY DUTY TO CONFIRM PRODUCT AND INSTALLATION COMPLIANCE WITH ALL APPLICABLE FEDERAL, STATE AND LOCAL REGULATIONS AND STANDARDS.

ANY MODIFIED UNITS ARE NON-RETURNABLE

As drawn As marked

Signed: _____ Date: _____

Printed Name: _____

LEAD TIME WILL START UPON RECEIPT OF SIGNED APPROVAL DRAWING

FOR INTERNAL USE ONLY
PROJECT SIGN OFF

SALES	
ENG.	
FAB.	
POWER	

DISTRIBUTOR'S NAME:		P.O.#	X
		W.O.#	X
DRAWN BY:	SR	DATE:	10/26/06
REFERENCE:	X	SCALE:	1:14
QUOTED LEAD TIME:	X	QUOTE #	X
			FILE NAME:
			21-007-055