

PREMIUM TRUCK SCISSOR DOCK LIFT - WL-100-6-610

ANY ADDITIONS, DELETIONS, OR OMISSIONS MUST BE CORRECTED ON THIS DRAWING AS THIS DRAWING WILL BE CONSIDERED ALL INCLUSIVE
 ALL GRAPHICS PROVIDED ARE FOR REFERENCE ONLY. IF CERTAIN DIMENSIONS ARE CRITICAL PLEASE VERIFY THOSE DIMENSIONS WITH YOUR SALESPERSON

STANDARD FEATURES

MODEL NUMBER: **WL-100-6-610**
 UNIT TO BE MOUNTED: AT SURFACE OR IN PIT (CIRCLE ONE)
 CAPACITY (EVENLY DISTRIBUTED): **6,000 LBS**
 OVERALL PLATFORM SIZE: **(72" X 120")**
 RAISED HEIGHT **70" ± 2"**
 LOWERED HEIGHT: **10"**
 REMOVABLE HANDRAILS AND 4" NON-REMOVABLE TOE BOARDS 45" HT W/ 21" MID-RAIL
 TRUCK BRIDGE IS 72" W X 18" L AT ROLLER END W/ CHAINS & HANDLES
 FRAME SIZE IS: **62" W X 118" L**
 SHIPPING WT APPROX: **3500 LBS ±**
 6 1/2 HP POWER UNIT (SEE BOTTOM OF PAGE)

W/ 8' OF HYDRAULIC HOSE
 -HAND-HELD CONTROL ON A 4'-20' COIL CORD
 REFER TO THE UNIT'S ELECTRICAL DIAGRAM FOR ELECTRICAL SERVICE REQUIREMENTS
 -INSTALL TO MEET ALL APPLICABLE STATE & LOCAL CODES FOR YOUR AREA!
 5" BEVELED TOE GUARD
ARCHITECTURAL REVIEW FOR CORRECTNESS OF PIT AND FOR COMPLIANCE TO LOCAL AND STATE CODES IS RECOMMENDED.

DIMENSION TOLERANCE ± 1/4"

SPECIAL FEATURES

NONE

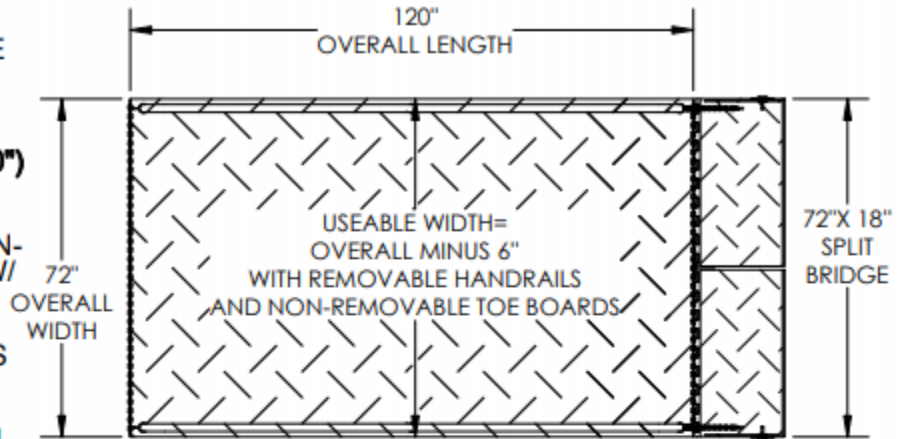

** STANDARD UNIT NOT INTENDED FOR SIDE CROSS LOAD **

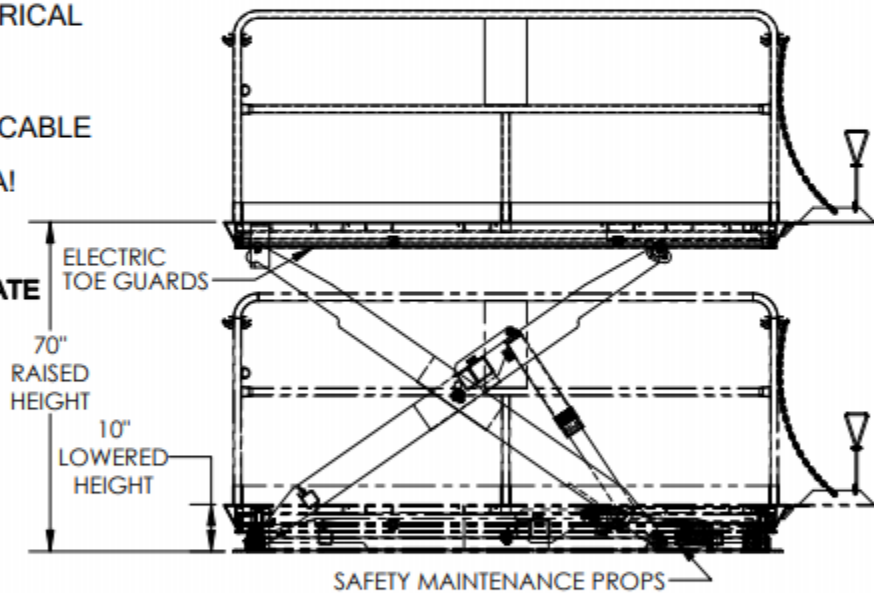

FOR INTERNAL USE ONLY PROJECT SIGN OFF	
SALES	
ENG.	
FAB.	
POWER	

HYDRAULIC UNIT
 OVERALL DIMENSIONS
 14"W x 33"L x 31"H
 (COMES W/ 8FT HOSE)

APPROVAL

I, THE UNDERSIGNED, AGREE THAT THE PRODUCT AS REPRESENTED SATISFIES DESIGN AND DIMENSION REQUIREMENTS. I ALSO ACKNOWLEDGE MY DUTY TO CONFIRM PRODUCT AND INSTALLATION COMPLIANCE WITH ALL APPLICABLE FEDERAL, STATE AND LOCAL REGULATIONS AND STANDARDS.

ANY MODIFIED UNITS ARE NON-RETURNABLE
 As drawn As marked

Signed: _____ Date: _____

Printed Name: _____

LEAD TIME WILL START UPON RECEIPT OF SIGNED APPROVAL DRAWING

POWER	AC	DC (12V)	AIR/OIL
MOTOR VOLTAGE	115	208	230 460
DEDICATED CIRCUIT REQUIRED 60Hz			
MOTOR PHASE	SINGLE	THREE	
CONTROL	HAND	FOOT	



DISTRIBUTOR'S NAME:		P.O.#
		X
		W.O.#
		X
DRAWN BY:	DATE:	SALES:
DLS	8/1/2016	X
REFERENCE:	SCALE:	FILE NAME:
X	1:36	
QUOTED LEAD TIME:	QUOTE #	
X	X	05-007-310