

TRUCK SCISSORS DOCK - WL-100-6-710 - PIT DIAGRAM

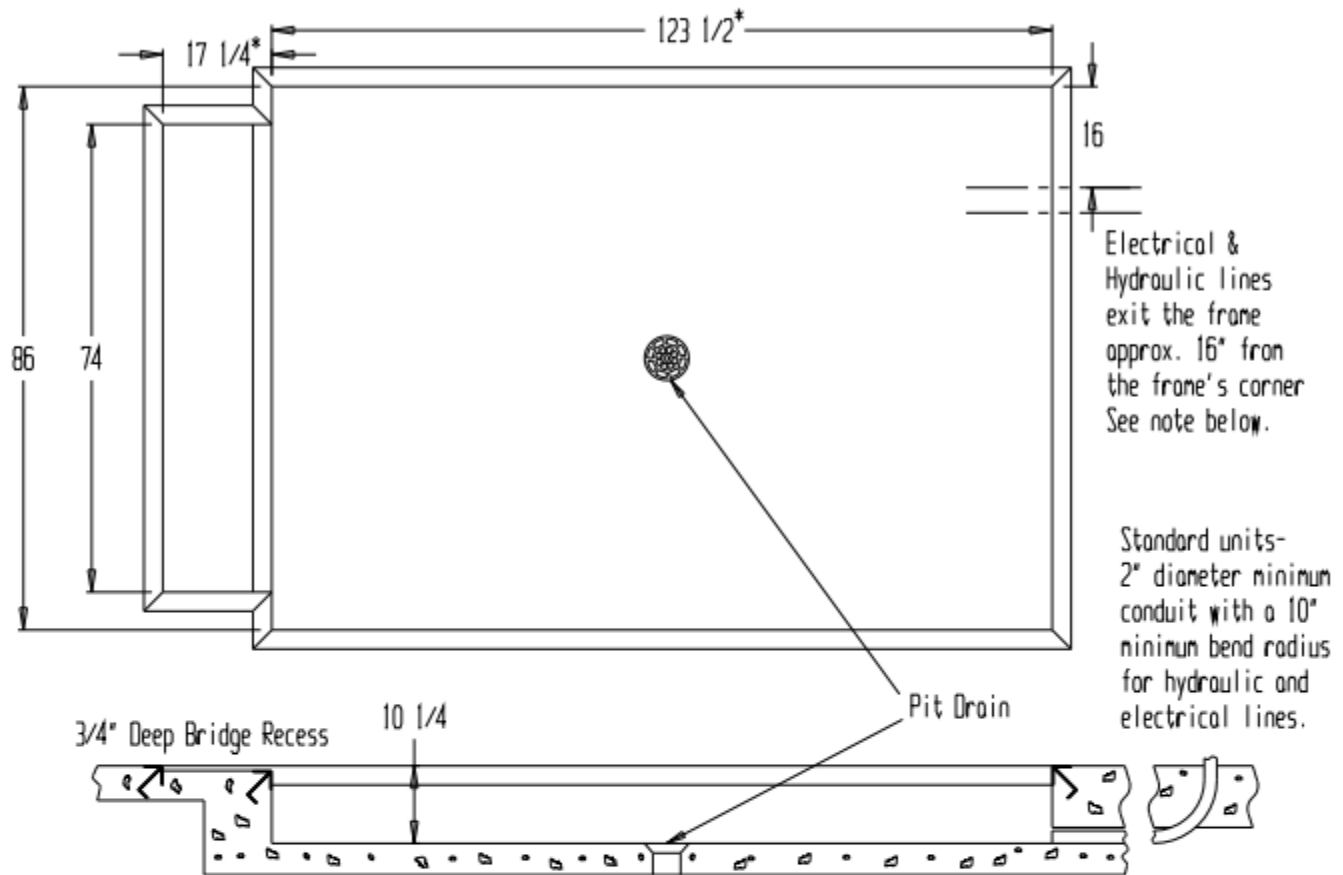

PIT FLOOR MUST BE LEVEL

** Any additions, deletions or omissions must be corrected on this drawing, as this drawing will be considered all inclusive. **
 ** All graphics provided are for reference only. If certain dimensions are critical please verify those dimensions with your salesperson **

- For standard lifts, run 2" dia. min. conduit with 10" min. radius bends between the power unit location and the lift's pit, for hydraulic and electrical lines. Conduit entry should be to either side of the pit, or to the end opposite where trailers will back up to unit.
- Follow all codes applicable to the installation's location. Pit work, bumper posts, curb angles, conduit, and the electrical supply installation is the responsibility of the owner or the installer. Unit must be mounted on a suitable concrete slab if not installed in a pit. Consult the building's architect to determine the adequate concrete and anchor requirements.
- Pit drains are to be installed to suit local codes and weather conditions.

PIT SPECIFICATIONS

Pit Width: 86"
 Pit Length: 123 1/2"
 Pit Depth: 10 1/4"

* UNIT WITH ALUMINUM BRIDGES
 ● PLATFORM LENGTH + 5"
 ● BRIDGE LENGTH - 2 1/4"

LIFT FEATURES- Model Number: WL-100-6-710

CAPACITY: 6,000 LBS
 WIDTH: 84" BRIDGE LENGTH: 72"
 LENGTH: 120" BRIDGE WIDTH: 16 1/2"
 LOWERED HEIGHT: 10" BRIDGE MAT'L: STEEL OR ALUM

DISTRIBUTOR'S NAME:		P.O.#: -
		V.O.#: -
DRAWN BY: E. JOHNSON	DATE: 10/29/03	SALES: -
REFERENCE: -	SCALE: 1:28	DRG./FILE NAME:
QUOTED LEADTIME: -	QUOTE #: -	05-007-013-005